

RoughCam[®] IPQ1656

User Manual



Table of contents

1	Introduction	5
2	Technical data	5
2.1	Illustration of the model key.....	5
2.2	Electrical parameters of the camera.....	7
2.3	Connection cable.....	7
2.3.1	Connection cable for models without heater (SKD01-T/ASKD02-T).....	7
2.3.2	Connection cable for models with heater (SKDP03-T/ASKDP03-T).....	8
2.3.3	Connection cable for model with cool.Jacket (SKD05-HT)	9
2.4	Video-technical characteristics	10
2.5	Other technical data	10
3	Safety Instructions	10
4	Installation	11
5	Electrical connection	13
5.1	Potential equalization	13
5.2	Connection and Fusing	14
5.2.1	Fusing	20
5.2.2	Plug assignments (RJ45).....	21
5.2.3	Tests prior to switching on the voltage	22
6	Working inside the camera housing.....	22
6.1	Work preparation:.....	23
6.2	Opening the pressure-resistant housing.....	23
6.3	Removing/inserting a SD memory card	25
6.4	Status LED	26
6.5	Hardware Reset	26
6.6	Closing of the housing.....	26
6.7	Battery.....	27
7	Network access and visualization	28
7.1	Browser Support.....	28
7.2	Assigning the IP address.....	28
7.3	Password/ Identification	29
8	Maintenance/ Modification/Repairs	30
9	Disposal/ Recycling	30
10	Drawings & 3D models	30
11	Further documentation.....	31

Table of Figures and Charts

Tab. 2-1 Model key	5
Fig. 2-1 Sectional view of SKD01-T	7
Fig. 2-2 Sectional view of ASKD02-T	8
Fig. 2-3 Sectional view of SKDP03-T	8
Fig. 2-4 Sectional view of ASKDP03-T	9
Fig. 2-5 Sectional view of SKD05-HT	9
Tab. 2-2. Other technical data	10
Tab. 4-1 Mounting Accessories	12
Fig. 5-1 RoughCam IPQ1656 Equipotential Bonding	13
Tab. 5-1 Equipotential Bonding	14
Fig. 5-2. Cable gland and supply line	14
Fig. 5-3 RoughCam IPQ1656 T10-VA2.3.K3.BOR2-N.H-xxx.N- T	15
Fig. 5-4 RoughCam IPQ1656 T10-VA2.3.K3.BOR2-N.H-005.N- P	15
Fig. 5-5 RoughCam IPQ1656 T10-VA2.3.K3.BOR2-LL.H-005.N- P	15
Fig. 5-6 RoughCam IPQ1656 T10-VA2.3.K3.BOR2-N.HH-010.N- T	16
Fig. 5-7 Video Tutorial ExtB-3	16
Tab. 5-2. Wire assignment of terminal box (without heater)	16
Tab. 5-3 Wire assignment of terminal box (model N/ASKD02-T)	17
Tab. 5-4 Wire assignment of terminal box (integrated heater).....	17
Tab. 5-5 Wire assignment of terminal box (model LL/ASKDP03-T).....	18
Fig. 5-8 Sample circuit of terminal box (without heater).....	18
Fig. 5-9 Sample circuit of terminal box (heater integrated).....	19
Fig. 5-10 Photo of the wired terminal box	19
Tab. 5-6 Wire assignment of terminal box ExtB-2 (SKD05-HT).....	20
Tab. 5-7 Recommendation for fusing	21
Fig. 5-11 Plug assignment, RJ45.....	22
Fig. 6-1 Removing the weather protection roof (1/2) (similar illustration).....	23
Fig. 6-2 Removing the weather protection roof (2/2) (similar illustration).....	23
Fig. 6-3 Opening the RoughCam IPQ1656 (similar illustration).....	24
Fig. 6-4 Mounting adapter with built-in components	25
Fig. 8-1 Axis IP Utility	29

History of revisions

Product: RoughCam® IPQ1656
 Title: User Manual for RoughCam® IPQ1656
 Doc. -Id. 240223-PT08BA-ES-ExCam-IPQ1656_en_rev.00.docx
 Author: Sabine Heinz
 Created: 07.05.2024

Rev. Index	Date	Name	Comment	Approved by the ATEX Supervisor
0	07.05.2024	S. Heinz	Compilation of the document, from the document of the user manual ExCam IPQ1656	
1				

1 Introduction

The RoughCam IPQ1656 is a powerful mega-pixel IP camera of the latest generation, with 4-megapixel resolution at 2688 x 1512 pixels. The camera has a high-definition television resolution. It is equipped with a powerful remote zoom and focus lens (with i-CS). The RoughCam series can be used for a wide range of industrial applications. The camera system is made for the harshest industrial conditions in the world. For further information, please visit our product page at

<https://www.samcon.eu/en/products/roughcam/roughcam-ipq1656/>

When designing the RoughCam IPQ1656, we focused very much on safety, mechanical precision and a high quality stainless steel.

2 Technical data

2.1 Illustration of the model key

1) Product-name	2) Type	3) Housing- combination	4) Temp.- range	5) Cable length [m]	6) Cable termin.
RoughCam IPQ1656	T10-	VA2.3.K3.BOR2-	N.H-	005.N-	P
	T10-	VA2.3.K3.BOR2-	N.H-	005.N-	T
	T10-	VA2.3.K3.BOR2-	N.H-	005.A-	P
	T10-	VA2.3.K3.BOR2-	N.H-	005.A-	T
	T10-	VA2.3.K3.BOR2-	LL.H-	005.N-	P
	T10-	VA2.3.K3.BOR2-	LL.H-	005.N-	T
	T10-	VA2.3.K3.BOR2-	LL.H-	005.A-	P
	T10-	VA2.3.K3.BOR2-	LL.H-	005.A-	T
	T10-	VA2.3.K3.BOR2-	N.HH-	010.N-	T

Tab. 2-1 Model key

Explanations:

- 1) **RoughCam IPQ1656** = Functional camera description of the RoughCam Series (technical data/ specification of the individual camera module)
- 2) **T10** = SAMCON Production- Type 10 (for safe areas)
- 3) **VA2.3.K3.BOR2** = Housing (stainless steel 1.4404) with large diameter
 $\varnothing_{VA2}=113\text{mm}$
VA2.3.K3.BOR2 = T07 VA2.3 housing with maximum body length ($L_R = 310\text{mm}$)

VA2.3.K3.BOR2 = K3 cable gland flange
VA2.3.K3.BOR2 = Borosilicate sight glass DIN7080 (standard, for video cameras within visible spectral range: $\lambda = 350\dots2000$ [nm] and photografical infrared range (NIR), not suitable for thermographic applications (MIR/ FIR))
- 4) **N.X** = Normal ambient temperature range, no heater installed ($T_{amb} > -20^\circ\text{C}$)
N.H = High temperature ($T_{amb} < +60^\circ\text{C}$)

- LL.H=** PTC heater installed ($T_{amb} > -60^{\circ}\text{C}$)
N.HH= Optional housing cooling cool.Jacket ($T_{amb} < +130^{\circ}\text{C}$)
- 5) **005.N =** Length of the connection line in meter at delivery; 5m is the standard cable length, max. cable length is: 005...100 [m]
005.N = Non armoured cable
005.A = Armoured cable
- 6) **P =** Plug- termination (standard)
CAT6, RJ-45 network plug (heavy duty), AWG 26-22, contact assignment acc. To specification EIA/TIA-568B
- T =** Terminal Box termination (optional)
4 x PoE Mode A connection (camera PoE)
24VDC (Heater) (see chapter electrical connection)

2.2 Electrical parameters of the camera

Supply of 24 V DC for the heating:

Voltage supply:	24 V DC
Power consumption:	approx. 40W@-60°C (temperature-dependent)

Power supply of the camera over Ethernet (PoE):

Voltage supply:	PoE, IEEE 802.3af/802.3at type 1 class 3
Reference voltage:	+48 V DC (44...54 V DC)
Maximum power consumption:	8.2 W
Typical power consumption:	5.1 W

2.3 Connection cable

Description:	Data transfer and power supply of the camera module (compliant with DIN EN 60079-14)
Jacket colour:	Green (GN), similar to RAL3001

2.3.1 Connection cable for models without heater (SKD01-T/ASKD02-T)

Systemcable SKD01-T:

Outside diameter:	9.10 ± 0.2 mm
Bending radius:	10x D _a when installed and 5x D _a after relocation
Data line:	4 x 2 x AWG22/1 CAT.6
Properties:	PUR halogen-free, flame-retardant, UV-resistant, chemical resistance, shielded

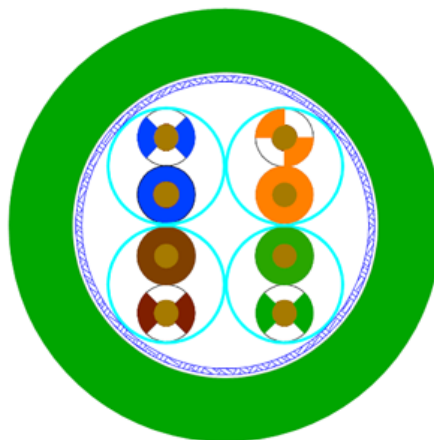

Fig. 2-1 Sectional view of SKD01-T

Systemcable ASKD02-T:

Outside diameter:	12.0 ± 0.4 mm
Bending radius:	20 x D _a when installed and 10 x D _a after relocation
Data line:	4 x 2 x AWG23/1 CAT.6
Properties:	PUR halogen-free, flame-retardant, UV-resistant, chemical resistance, shielded (see www.samcon.eu)

Quicklink:

https://www.samcon.eu/fileadmin/documents/en/60- Assembling and mounting/ASKD02-T_Datasheet.pdf

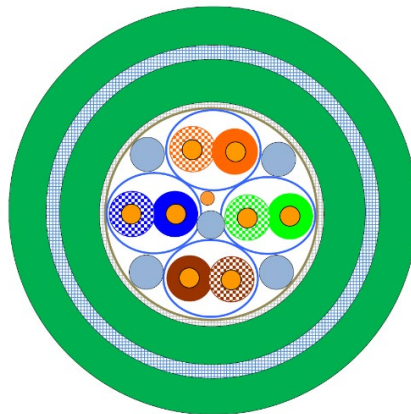

Fig. 2-2 Sectional view of ASKD02-T

2.3.2 Connection cable for models with heater (SKDP03-T/ASKDP03-T)
Systemcable SKDP03-T:

Outside diameter:	12.40 ± 0.3 mm
Bending radius:	8 x D _a when installed and 4 x D _a after relocation
Data line:	4 x 2 x AWG23/1 CAT.6
Performance elements:	3G1.5 (BK-BU-GN/YE)
Properties:	PUR halogen-free, flame-retardant, UV-resistant, chemical resistance, shielded

Quick link:

https://www.samcon.eu/fileadmin/documents/en/60-Assembling%26mounting/SKDP03-T_Datasheet.pdf

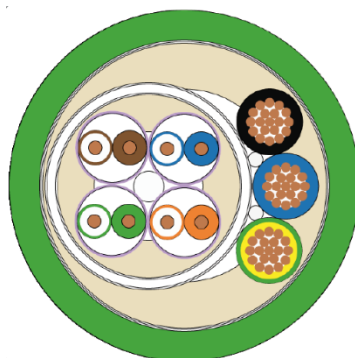

Fig. 2-3 Sectional view of SKDP03-T

Systemcable ASKDP03-T:

Outside diameter:	15.50 ± 0.6 mm
Bending radius:	15 x D _a when installed and 10 x D _a after relocation
Data line:	4 x 2 x AWG23/1 CAT.6
Performance elements:	3G1.5 (BK-BU-GN/YE)
Properties:	PUR halogen-free, flame-retardant, UV-resistant, chemical resistance, shielded

Quicklink:

https://www.samcon.eu/fileadmin/documents/en/60-Assembling%26mounting/ASKDP03-T_Datasheet.pdf

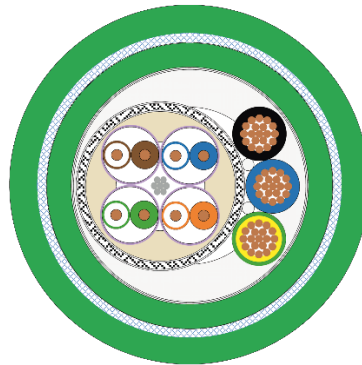

Fig. 2-4 Sectional view of ASKDP03-T

2.3.3 Connection cable for model with cool.Jacket (SKD05-HT)

Systemcable SKD05-HT:

Outside diameter:	6.60 ± 0.2 mm
Bending radius:	8 x D _a when installed and 4 x D _a after relocation
Data line:	4 x 2 x AWG26/7 CAT.6
Properties:	FEP, flame-retardant, UV-resistant, chemical resistance, for extreme hot temperatures

Quick link:

https://www.samcon.eu/fileadmin/documents/en/60-Assembling%26mounting/SKD05-HT_Datasheet.pdf

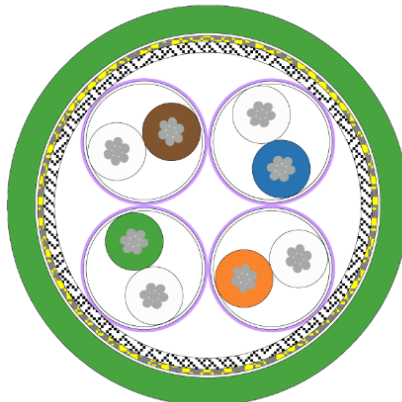

Fig. 2-5 Sectional view of SKD05-HT

2.4 Video-technical characteristics

We use the AXIS P1377 network camera in a pressure-resistant enclosure. For details, please refer to the Product Documentation, video-technical data of AXIS®:

<https://www.axis.com/products/axis-q1656>



2.5 Other technical data

	Camera	Terminal box
Permissible ambient temperature	-20°C ... +60°C (for PoE power supply) -60°C ... +60°C (In the event of additional 24 V DC power supply)	-60°C ... +55°C
Protection class as per EN 60529/IEC 529	IP66/68 (Test conditions: 24h/3m water column 5°C)	IP66
Housing material	stainless steel, mat. no. 1.4404	polyester resin
Weight	about 7.8 kg	about 1 kg
Dimensions	D113mm x 310mm	145mm x 145mm x 71mm

Tab. 2-2. Other technical data

3 Safety Instructions

It is absolutely mandatory to observe the national safety regulations and regulations for prevention accidents, as well as the safety instructions given below in this User Manual!



Attention!

Only original parts of SAMCON Prozessleittechnik GmbH may be used for repairs. Repairs concerning the explosion protection may only be carried out in accordance with the nationally applied regulations and by SAMCON Prozessleittechnik GmbH.



Attention!

Prior to installation, take external sources of heat or cold into account! The temperature ranges prescribed for storage, transportation, and operating must be adhered to!

4 Installation

For erecting and operating the camera, the relevant national regulations, as well as the generally accepted rules of technology shall prevail. Before mounting the camera, thoroughly check it for any transport damage, especially on the housing and cable. Installation, electrical connection and the first start must only be carried out by qualified specialists.

Work preparation:



Attention!

Prepare your work carefully and in accordance with the relevant regulations.

To ensure the best image quality delivered by the network camera, plan the installation site carefully (consider light conditions, object distance or size, angle and minimum object distance to the focus).

- Use appropriate tools and aids.
- When working, ensure a safe stand.
- Make sure that any static charge is avoided



Attention!

Please observe the national security, installation and accident prevention regulations (e.g. DIN EN 60079-14) and the safety instructions in this User Manual, as well as the ones in the Installation Guidelines!

The RoughCam® IPQ1656 consists of a flame-proof camera housing and, optionally, a terminal box. Both units are connected via a reinforced 5 m cable. Mount the camera according to the desired field of view. Install the terminal box so that a good accessibility is provided, in order to facilitate electrical connection.



Attention!

Please pay attention to the national and local regulations for mounting heavy loads. If in doubt, take appropriate security measures.

Drawings for drill hole patterns and further information can be viewed on our product page:

Quick link:

<https://www.samcon.eu/en/products/roughcam/roughcam-ipq1656/>



Option mounting accessories

<p>Wall bracket WMB-...</p>		<p>WALL MOUNT BRACKET WMB-VA2.3 Wall bracket for devices of T10-VA2.3 series Suitable for hanging the camera on walls. Material: stainless steel 1.4404 Load bearing: 45 kg Dimensions: 445 x 140 x 185 mm</p>
<p>Weather protection roof WPR-...</p>		<p>WEATHER PROTECTION ROOF WPR-VA2.3 Weather protection roof for cameras of the T10-VA2.3-Series</p>
<p>Pole adapter PMB-...</p>		<p>WALL MOUNT BRACKET PMB-VA2.3 Pole adapter for VA wall mount Material: stainless steel 1.4404 Suitable for pole diameters between 50 and 105 mm Load-bearing capacity: 45 kg Dimensions: 120 x 180 (x 130 bei Mast Ø 60 mm)</p>

Tab. 4-1 Mounting Accessories

5 Electrical connection



Attention!

The electrical connection of the equipment may only be carried out by officially qualified and skilled personnel!



Attention!

It is absolutely necessary to ground the RoughCam® series housing via a PA connection.

The delivered RoughCam® IPQ1656 is equipped with an electrical connection cable of the type SKD01-T/ASKD02-T (models N.H) or the type (A)SKDP03-T (models LL.H). The maximum transmission range from the camera to the next active network interface is 100 meters and can be individually specified by the client. The user is NOT authorised to do electrical connection procedures inside the enclosure.

5.1 Potential equalization

The potential equalization/grounding of the camera body is absolutely necessary, in order to avoid static charges and thus formation of sparks. For this purpose, a screw terminal is provided at the rear side, at the bottom (right) (see Figure 5.1). The cross-section of the equipotential bonding should comply with the National Ground Rules (at least 4 mm²).

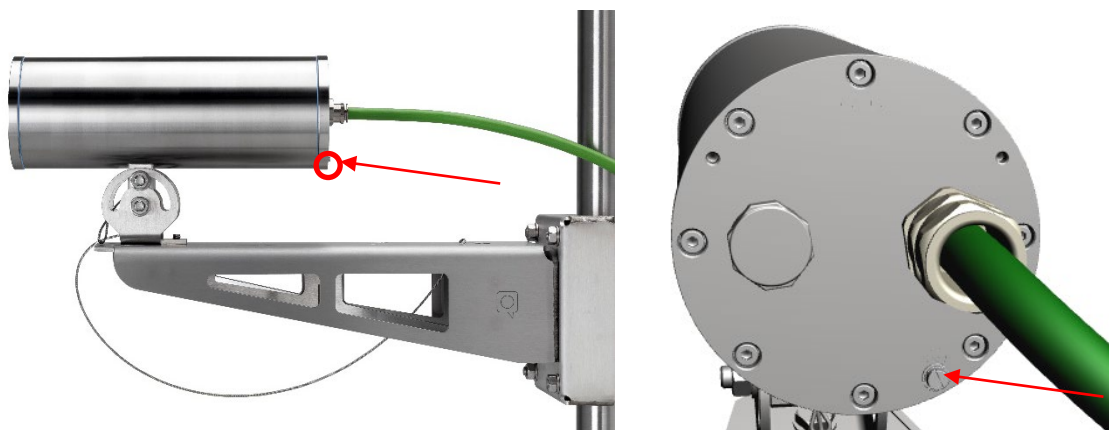

Fig. 5-1 RoughCam IPQ1656 Equipotential Bonding

Wiring table:

Potential	Colour (IEC 60757)	Cross-section	Comment
PA	GN/YE	4 mm ² (rigid)	Terminal: slotted screw M4x0.7 (DIN 84) with washer Ø9mm (DIN 125A), Keep 3Nm tightening torque!

Tab. 5-1 Equipotential Bonding

5.2 Connection and Fusing

Cable gland ADE 1F2 for non-armoured cables

Cable gland ADE 4F for armoured cables

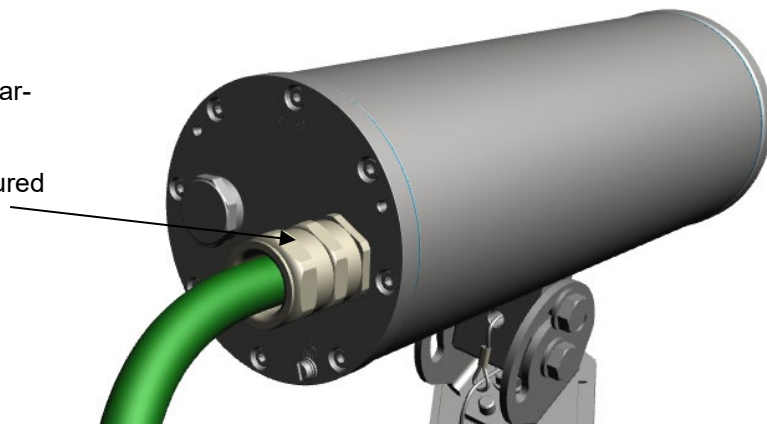

Fig. 5-2. Cable gland and supply line

The green system cable is intended for communication and data transfer to the connected network devices and, at the same time, for voltage supply (PoE) to the camera. To ensure the power supply of RoughCam IPQ1656 (*Powered Device/ PD*), it is necessary to make sure that the power-over-Ethernet provider (*Power Sourcing Equipment/ PSE*) on the connection side (for example PoE Midspan PoE injector, switch, etc.) fulfils the specification IEEE 802.3af and 802.3at type 1 Class 3 ("*classification current: 26-30 mA @48VDC, max. feed-in power (power source equipment): 15.4 W, maximum offtake (power device): 6.49 - 12.95 W*"). The data transfer of the RoughCam IPQ1656 series is done via a 100 Mbit/s Ethernet connection (100BASE-TX).

The figures 5.3 - 5.6 illustrate the potential cable terminations of the ExCam IPQ1656. Possible terminations are: terminal box or plug.

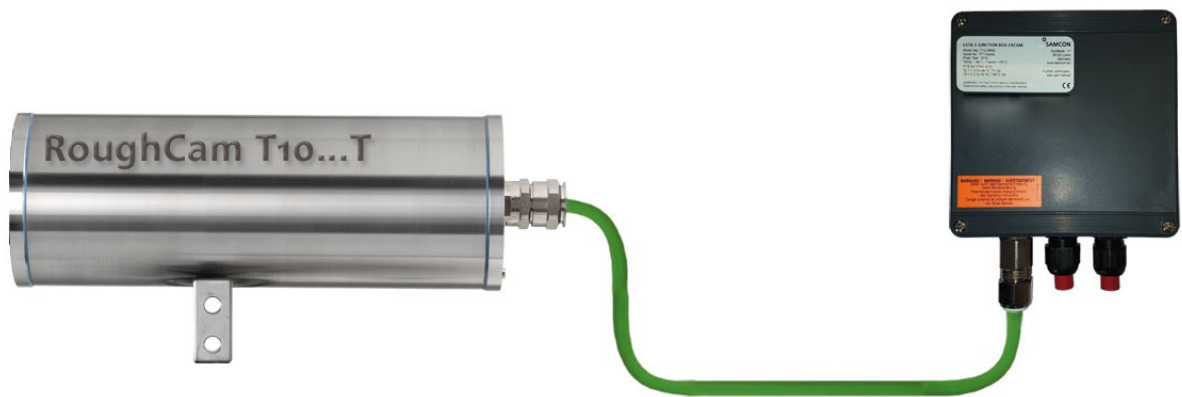

Fig. 5-3 RoughCam IPQ1656 T10-VA2.3.K3.BOR2-N.H-xxx.N-I



Fig. 5-4 RoughCam IPQ1656 T10-VA2.3.K3.BOR2-N.H-005.N-P

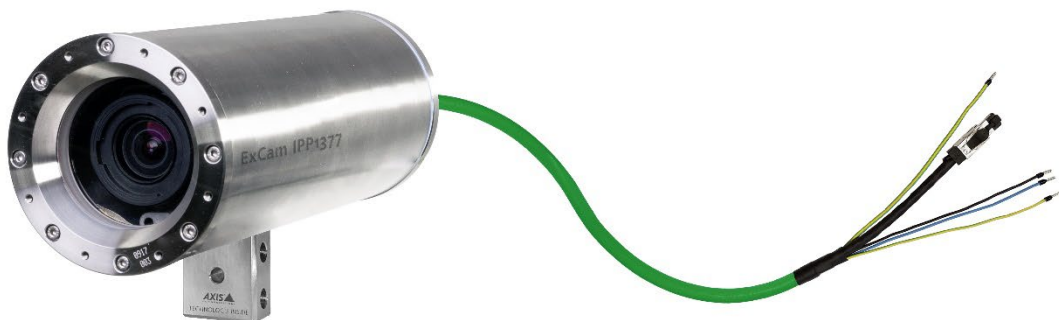

Fig. 5-5 RoughCam IPQ1656 T10-VA2.3.K3.BOR2-LL.H-005.N-P

Figure 5.6 shows RoughCam IPQ1656 with active cooling cool.Jacket.

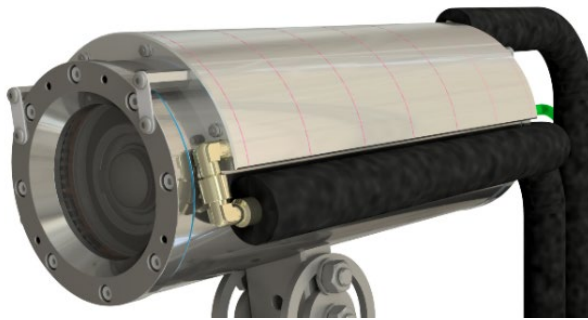

Fig. 5-6 RoughCam IPQ1656 T10-VA2.3.K3.BOR2-N.HH-010.N-I

Video Tutorial:

Please view our video tutorial:

“SAMCON 01 Wiring the cable SKDP03-T to the junction box”

<https://go.samcon.eu/v01>



Fig. 5-7 Video Tutorial ExtTB-3

The pin assignment of the SKD01-T is executed in accordance with the standard EIA/TIA-568B for 100BaseTX and 24VDC, as follows:

Camera (T568B)	Colour SKD01-T (IEC60757)	Terminal	Cross-sectional surface	Comment
Tx+	WH / OG	1	0.32 mm ²	Solid conductor
Tx-	OG	2	0.32 mm ²	Solid conductor
Rx+	WH / GN	3	0.32 mm ²	Solid conductor
Rx-	GN	4	0.32 mm ²	Solid conductor
(PoE +48 VDC)	WH / BU	5	0.32 mm ²	Solid conductor
(PoE +48 VDC)	BU	6	0.32 mm ²	Solid conductor
(PoE GND)	WH / BN	7	0.32 mm ²	Solid conductor
(PoE GND)	BN	8	0.32 mm ²	Solid conductor
GND/SHD	YE / GN	PE	2.5 mm ²	Flex

Tab. 5-2. Wire assignment of terminal box (without heater)

The pin assignment of the ASKD02-T is executed in accordance with the standard EIA/TIA-568B for 100BaseTX and 24VDC, as follows:

Camera (T568B)	Colour ASKD02-T (IEC60757)	Terminal	Cross-sectional surface	Comment
Reinforcement	YE / GN	PE	2.5 mm ²	Flex
Tx+	WH / OG	1	0.26 mm ²	Solid conductor
Tx-	OG	2	0.26 mm ²	Solid conductor
Rx+	WH / GN	3	0.26 mm ²	Solid conductor
Rx-	GN	4	0.26 mm ²	Solid conductor
(PoE +48 VDC)	WH / BU	5	0.26 mm ²	Solid conductor
(PoE +48 VDC)	BU	6	0.26 mm ²	Solid conductor
(PoE GND)	WH / BN	7	0.26 mm ²	Solid conductor
(PoE GND)	BN	8	0.26 mm ²	Solid conductor
GND/SHD	YE / GN	PE	2.5 mm ²	Flex

Tab. 5-3 Wire assignment of terminal box (model N/ASKD02-T)

The pin assignment of the SKDP03-T is executed in accordance with the standard EIA/TIA-568B for 100BaseTX and 24VDC, as follows:

Camera (T568B)	Colour SKDP03-T (IEC60757)	Terminal	Cross-sectional surface	Comment
Tx+	WH / OG	1	0.26 mm ²	Solid conductor
Tx-	OG	2	0.26 mm ²	Solid conductor
Rx+	WH / GN	3	0.26 mm ²	Solid conductor
Rx-	GN	4	0.26 mm ²	Solid conductor
(PoE +48 VDC)	WH / BU	5	0.26 mm ²	Solid conductor
(PoE +48 VDC)	BU	6	0.26 mm ²	Solid conductor
(PoE GND)	WH / BN	7	0.26 mm ²	Solid conductor
(PoE GND)	BN	8	0.26 mm ²	Solid conductor
GND/SHD	YE / GN	PE	2.5 mm ²	Flex
L+	BK	9	1.5 mm ²	L+ 24VDC
L-	BU	10	1.5 mm ²	L- 24VDC
PE	YE / GN	PE	1.5 mm ²	PE

Tab. 5-4 Wire assignment of terminal box (integrated heater)

The pin assignment of the ASKDP03-T is executed in accordance with the standard EIA/TIA-568B for 100BaseTX and 24VDC, as follows:

Camera (T568B)	Colour ASKDP03-T (IEC60757)	Terminal	Cross-sectional surface	Comment
Reinforcement	YE / GN	PE	2.5 mm²	Flex
Tx+	WH / OG	1	0.26 mm ²	Solid conductor
Tx-	OG	2	0.26 mm ²	Solid conductor
Rx+	WH / GN	3	0.26 mm ²	Solid conductor
Rx-	GN	4	0.26 mm ²	Solid conductor
(PoE +48 VDC)	WH / BU	5	0.26 mm ²	Solid conductor
(PoE +48 VDC)	BU	6	0.26 mm ²	Solid conductor
(PoE GND)	WH / BN	7	0.26 mm ²	Solid conductor
(PoE GND)	BN	8	0.26 mm ²	Solid conductor
GND/SHD	YE / GN	PE	2.5 mm²	Flex
L+	BK	9	1.5 mm ²	L+ 24VDC
L-	BU	10	1.5 mm ²	L- 24VDC
PE	YE / GN	PE	1.5 mm ²	PE

Tab. 5-5 Wire assignment of terminal box (model LL/ASKDP03-T)

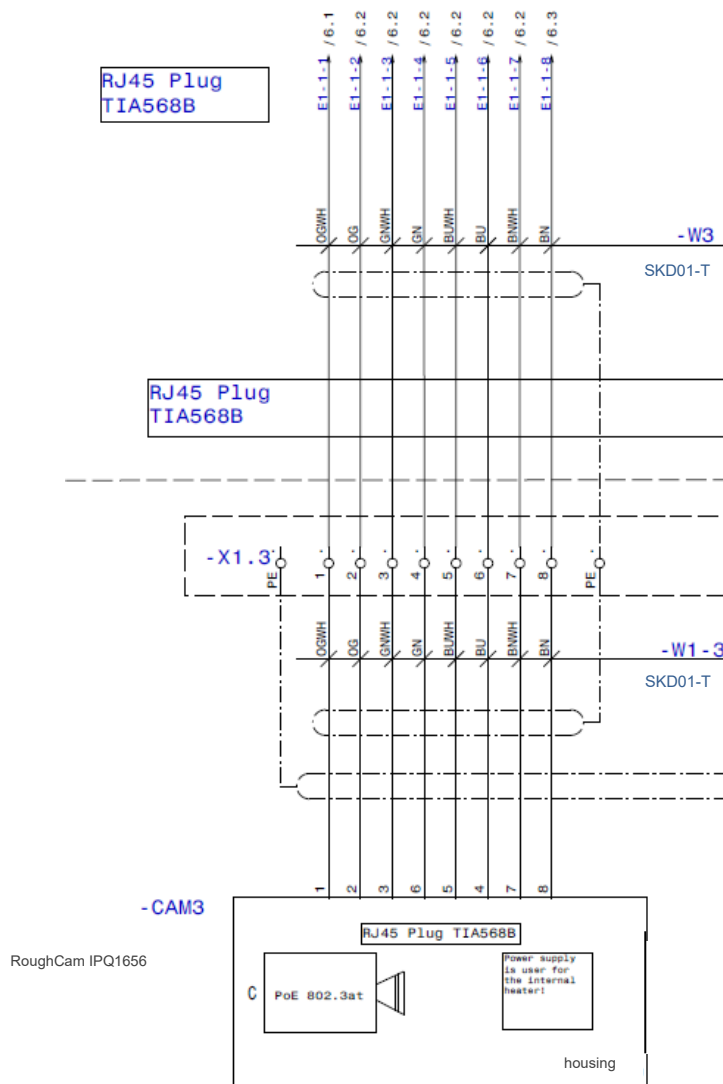

Fig. 5-8 Sample circuit of terminal box (without heater)

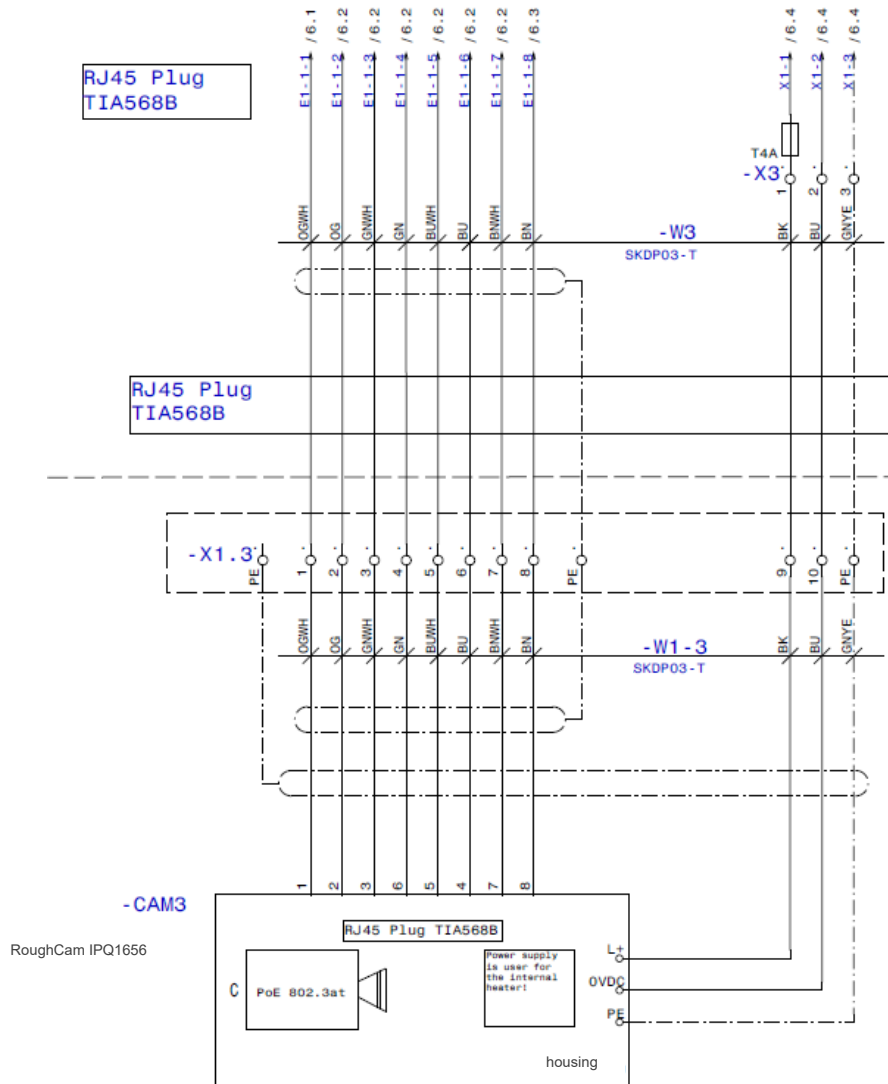

Fig. 5-9 Sample circuit of terminal box (heater integrated)

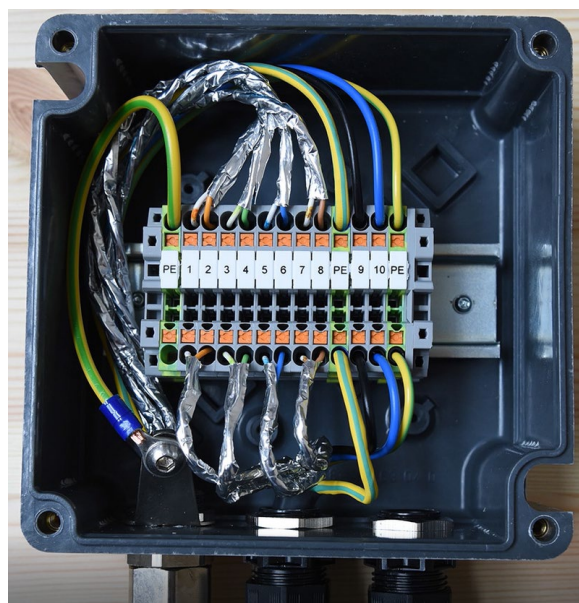

Fig. 5-10 Photo of the wired terminal box

Attention!

Introduce the foiling up to about 15 mm close to the terminals, in order to prevent alien crosstalk. Make sure that the foiling cannot cause any short circuit of the data pairs!

Attention!

Bring the twisted pair composite up to about 10 mm close to the terminals, in order to ensure interference immunity.

Attention!

Use only terminals approved by SAMCON.

Attention!

Finally, check your network installation with a Class-D Link Test.

Note:

If the camera is equipped with a camera cooling system (SAMCON cool.Jacket for model key type N.HH), the wiring is executed via the cable SKD05-HT.

The pin assignment of the SKD05-HT is executed in accordance with the standard EIA/TIA-568B as follows:

Camera (T568B)	Colour SKD05-HT (IEC60757)	Terminal Box	Cross-sectional surface	Comment
Tx+	WH / OG	1	0.14 mm ²	Solid conductor
Tx-	OG	2	0.14 mm ²	Solid conductor
Rx+	WH / GN	3	0.14 mm ²	Solid conductor
Rx-	GN	4	0.14 mm ²	Solid conductor
(PoE +48 VDC)	WH / BU	5	0.14 mm ²	Solid conductor
(PoE +48 VDC)	BU	6	0.14 mm ²	Solid conductor
(PoE GND)	WH / BN	7	0.14 mm ²	Solid conductor
(PoE GND)	BN	8	0.14 mm ²	Solid conductor
GND/SHD	YE / GN	PE	2.5 mm ²	Flex

Tab. 5-6 Wire assignment of terminal box ExTB-2 (SKD05-HT)

A suitable water supply (cold water supply) must be provided by the customer (for more information, please refer to the data sheet for the corresponding cool.Jacket).

5.2.1 Fusing

PoE power supply requires no fuses.

The power supply fusing depends on the cable cross-section and length.



Attention!

Recommendation for fusing relates to 40W@24VDC at 100 meters 1.5 mm²



Attention!

When the heating switches on, high current peaks occur! Use slow-blow fuses.



Attention!

Please pay attention to the national and international regulations regarding selectivity and line protection.

Potential/ Wire no.	Colour (IEC60757)	Conductor	Voltage	Maximum power consumption/fusing:
L+ / 1	BK	1.5mm ² , stranded wire	+24 V DC	40 W of continuous power Fine-wire fuse (L+) 4000 mA -T- slow-blow (high inrush load!)
L- / 2	BU	1.5mm ² , stranded wire	0 VDC / GND	
PE	YE/GN	1.5mm ² , stranded wire	PE	

Tab. 5-7 Recommendation for fusing

5.2.2 Plug assignments (RJ45)

The data transfer of the RoughCam IPQ1656 uses a 100 Mbit/s Ethernet connection (100BASE-TX).

If the cable termination uses a plug, the latter should be plugged into the RJ45 PoE slot of the network device (PSE). Prior to connecting it to the camera, the network device (PSE) can already be supplied with power, hence there is no „power ON“ priority which has to be observed.



Attention!

Use appropriate RJ45 plugs! Check the cable shielding, cross-section and the outside diameter!



Attention!

It is imperative to ensure a correct routing of the individual wires according to the EIA/TIA-568B"



Attention!

Finally, check your network installation with a Class-D Link Test.

Detailed instructions on how to connect a RJ45 plug are available in our video tutorial: "SAMCON 03 Mounting and installing the RJ45 jack to SAMCON cables"
<https://go.samcon.eu/v03>

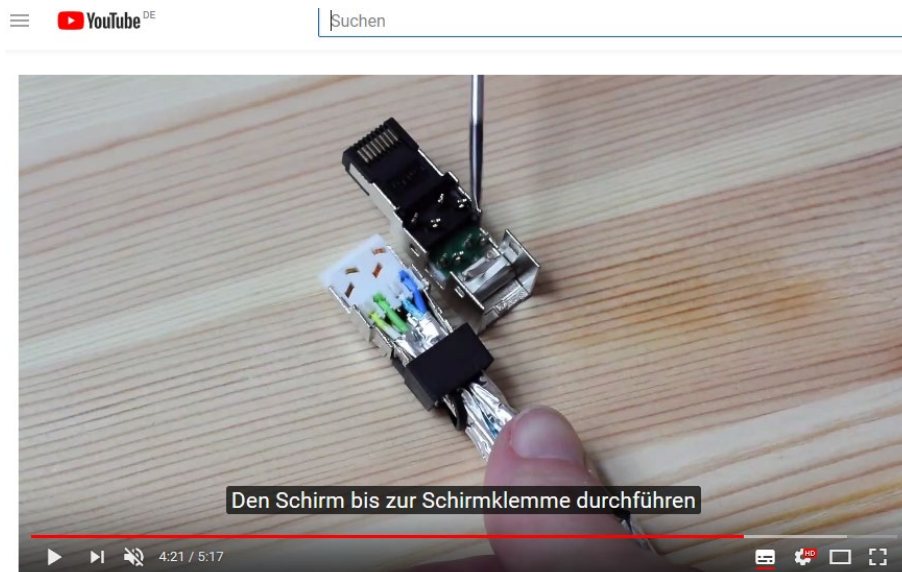

Fig. 5-11 Plug assignment, RJ45

5.2.3 Tests prior to switching on the voltage



Attention!

Prior to starting the device, perform all tests as indicated by the national regulations. Furthermore, check the correct function and installation of the device in accordance with this User Manual and other applicable regulations.



Attention!

Incorrect installation and operation of the camera may lead to a loss of warranty!



Attention!

Do not switch on the camera at temperatures below 0°C!

6 Working inside the camera housing

The customer may open the housing only if it is absolutely necessary. Only exchanging the SD memory card or a hardware reset are reasons for this.

6.1 Work preparation:



Attention!
 Prepare your work carefully and in accordance with the relevant regulations.

- Use suitable tools/aids
- Ensure that you have a secure footing when working
- Prevent static charge at all costs

6.2 Opening the pressure-resistant housing

If the RoughCam IPQ1656 is equipped with a weather protection roof (optional accessory), remove the roof before you start working! To do so, untighten the 4x12mm lens screws M4*0.7 at the front and rear sides of the bracket holders (Fig. 6-1).

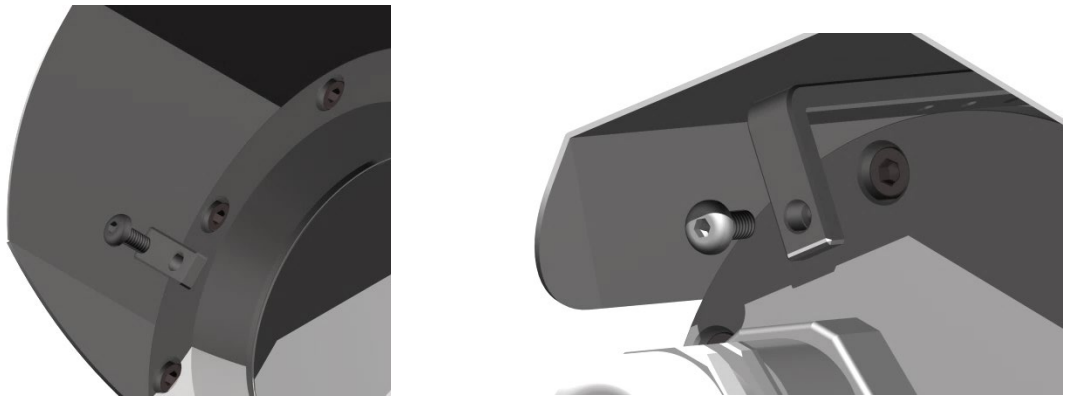

Fig. 6-1 Removing the weather protection roof (1/2) (similar illustration)

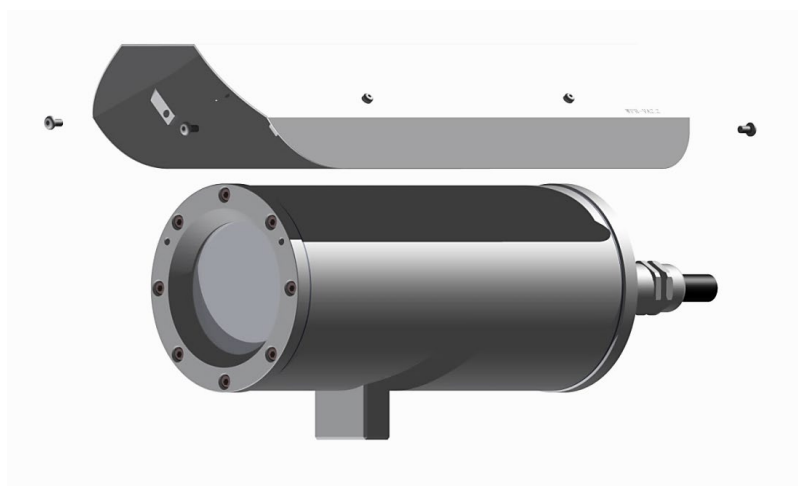

Fig. 6-2 Removing the weather protection roof (2/2) (similar illustration)

To open the RoughCam IPQ1656's stainless steel housing of, loosen the eight cylinder-head hexagon screws (DIN 912/ ISO 4762) together with their spring rings (DIN 127A) on the rear side of the cable and power supply flange (see Fig. 6-3).

Caution: Do not touch the screw threads with your skin or clothes! On the threads, there is LOCTITE® 243™ (chemical basis is dimethacrylate ester) applied to prevent the bolted connection from unintentional loosening because of impacts and vibrations and to seal them tightly. It is not permitted for the customer to open the front-side sight glass flange! There is no need of such an action.

Carefully pull out the cable and supply flange to the rear, as straight as possible. Because of negative pressure, it may be difficult to remove the flange. The cylindrical clearance fit (H8f7 - DIN ISO 286) of the camera body and flange may not be tilted! Risk of damage to the flame-proof gap (DIN EN 60079-1:2012)!

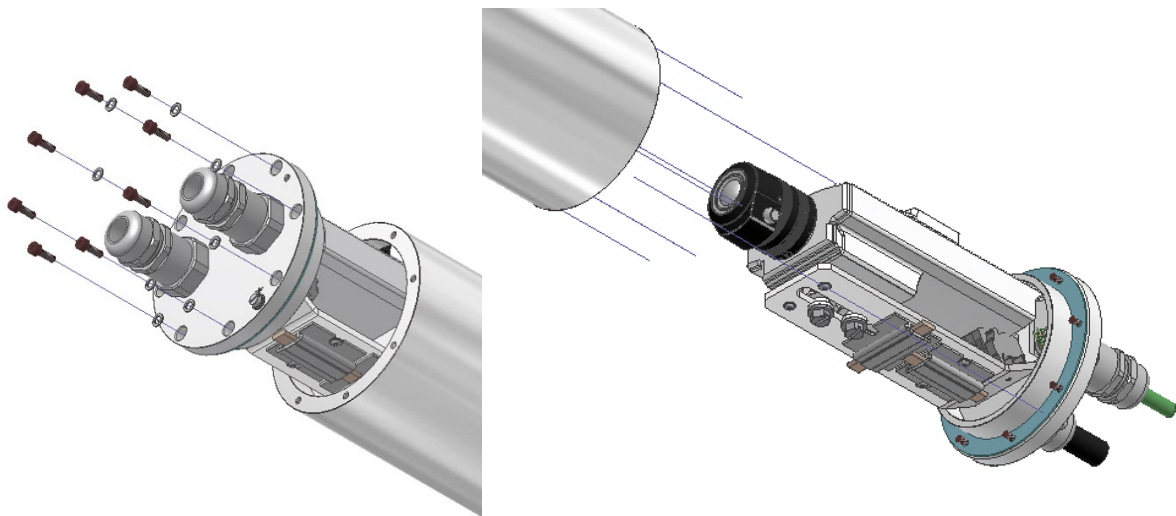
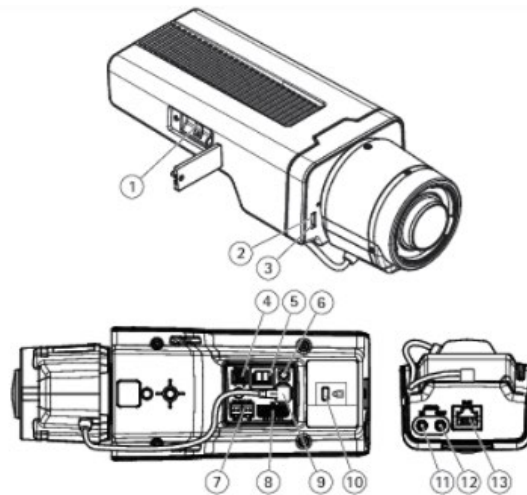

Fig. 6-3 Opening the RoughCam IPQ1656 (similar illustration)

Attention: The mounting adapter with the housing's PTC heater, camera module and optics, as well as the temperature control and (if applicable) auxiliary relays and terminal box are fixed on the cable and supply flange. Dealing with these components, too, you have to work very carefully and precisely in order to avoid canting and damage to the in-built components!

Caution: Do not touch the cylindrical fit surface with your skin or clothes! On the surface, there is oil lubricating paste to protect the surface against fretting corrosion and mechanical stresses.

When you open the housing, heed that you do not damage the GYLON® flat seal (blue, RAL5012) and do not make it dirty. The flat gasket is loosely attached to the cable and power supply flange. It is fixed only by the bolted connections!



1. microSD card slot
2. Status LED
3. Built-in microphone
4. Power connector (DC)
5. T92G20 connector
6. Control button
7. RS485/422 connector
8. I/O connector
9. i-CS connector (compatible with P-iris and DC-iris)
10. Security slot
11. Audio in (analogue/digital)
12. Audio out
13. Network connector (PoE)

Fig. 6-4 Mounting adapter with built-in components

6.3 Removing/inserting a SD memory card

Note:

The RoughCam IPQ1656 disposes of a micro SDHC memory card slot (see Fig. 6-4 1). Saved video files can be played and deleted via the web interface. They are also available in a download list. Moreover, the videos available on the memory card can also be accessed via an FTP server in the network.

If the memory card has to be replaced by the user, it should be, as far as possible, empty and pre-formatted with an ext4 or vFAT file system.



When touching electrical components, observe potential equalization (grounding of the body): carry electrostatic-discharge clothes, a PE wristband etc.!

6.4 Status LED

The user can see the Status LED only if the camera housing is open.

6.5 Hardware Reset

To re-set all parameters of the RoughCam IPQ1656 (including the IP address) to default setting, a hardware reset has to be carried out.

The parameters can be either reset via the web interface or manually. If the camera in the network can no longer be reached or its state is uncontrollable, the reset should be performed manually. To do so, proceed as follows:

1. Disconnect the camera installation module (Axis Q1656) from the power supply.
2. Press and hold the control button 13 (see the illustration 6-4) and, at the same time, connect the system to the voltage supply (PoE).
3. Press and hold the control button until status indicator 2 (Fig. 6-4) lights yellow (wait about 30 seconds).
4. Release the control button. When the status indicator lights green (it can take about 1 minute), Q1656 will be reset to the factory settings axis. If there is a DHCP server in the network, the IP address will be the following: 192.168.0.90 (subnet masking 255.255.255.0).
5. IP address and password can be redefined. If the hardware reset is not satisfactory, or the network camera shows serious conflicts, or does not work as usually (errors in the browser visualisation, frozen images, control commands no longer processed, slowing down of the system, etc.), it may be necessary to re-install the current firmware, or to install an update (see Chapter 8).

6.6 Closing of the housing

For closing the housing, proceed in reverse order as when opening. Use exclusively original screws included in the supply.

The cable and power-supply flange (K3) is fixed by 8 cylinder-head screws M4*0.7 (ISO metric right-turning) with 12 mm thread length (DIN 912/ ISO 4762, grade 6g). Materials of bolted connections are identical to the pressure-resistant stainless steel housing (standard material no. 1.4404 AISI316L). Check whether the threaded holes are undamaged and clean. Before closing, it is also absolutely imperative to check the flame-proof gap (circular cylindrical fit).

**Attention!**

Do not lock-in any foreign objects in the housing.

Dismantled screw locks (spring washers DIN 127A) must be used again.

The GYLON® gasket must be used in undamaged condition, according to the flange hole pattern, and placed between the flange and the body. The lateral position of the flat surface/contact surface is arbitrary.

If, when closing the housing, you see that the surface of the fitting gap is dirty or insufficiently lubricated, clean it with a clean cloth and de-grease it with a suitable cleaning agent. Then re-grease it with lubricant suitable for this specific application (e.g., Molykote® P-40 gel for standard applications or special grease OKS 403 in the event of heavy seawater influence).

The screwed connections of flange and body components must always be tightened *crosswise* at a torque of **3 Nm**! Do not tighten the screws too strongly! It can cause rupture of the cylinder head or over-stretching the threads, and thus leading to an impairment of the pressure resistance or ignition protection class!



Cylinder-head bolts for explosion-proof connection of the camera body with the flange component must always be tightened at a 3 Nm torque - crosswise and evenly!

6.7 Battery

RoughCam IPQ1656 is equipped with a high-temperature resistant Panasonic button cell BR2330A/VAN. This cell supplies energy to the internal real time clock (RTC). The customer is not allowed to replace the battery! In this case, please contact the manufacturer.

7 Network access and visualization

The most important procedures of the camera's initial commissioning are described below. The configuration menu of the web surface allows an intuitive navigation and offers several configuration possibilities. For detailed documentation and information how to use the web Interface, please see the User Manual for Axis or visit the following website:

<https://www.axis.com/products/axis-q1656>



The delivered RoughCam IPQ1656 is set to the applicable net frequency (50Hz or 60Hz). If the camera is used at a location with a differing net frequency, the image might start to flicker, particularly in surroundings with fluorescent tubes. In such a case, the applicable settings have to be carried out within the menu "System Options > Advanced > Plain Config".

User: root
Password: root

7.1 Browser Support

A list of the currently supported web browsers, operating systems, required add-ons, etc. can be viewed at:

http://www.axis.com/techsup/cam_servers/tech_notes/browsers.htm

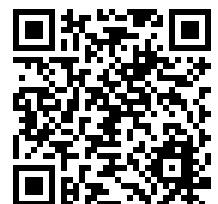

7.2 Assigning the IP address

The RoughCam IPQ1656 is intended for use in an Ethernet network and requires an IP address to access and control it. In most of today's networks, a DHCP server is integrated. This server automatically assigns an IP address.

If there is no DHCP server available in the network, the IP default address of RoughCam IPQ1656 is "**192.168.0.90**" (**subnet masking 255.255.255.0**).

With the "AXIS IP Utility", it is possible to determine the IP address under Windows; the included USB stick contains this application.



If it is not possible to assign the IP address, it might be necessary to change the firewall settings!

The "AXIS IP Utility" tool automatically recognizes all RoughCam devices and visualises them in the device list. It can also be used to manually assign a static IP address. For this purpose, the RoughCam IPQ1656 network camera should be installed in the same physical network segment (physical subnet) as the computer on which the AXIS IP Utility is running. The network signature of RoughCam IPQ1656 is "AXIS Q1656" (see Fig. 8-1). MAC address and serial number for clear device identification are also detected and displayed.

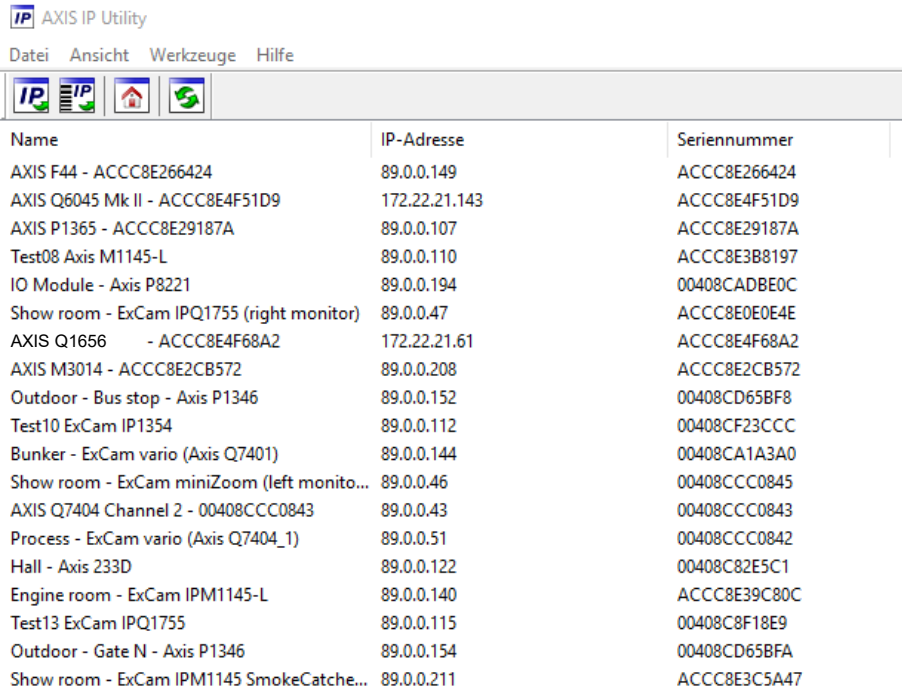

Name	IP-Adresse	Seriennummer
AXIS F44 - ACCC8E266424	89.0.0.149	ACCC8E266424
AXIS Q6045 Mk II - ACCC8E4F51D9	172.22.21.143	ACCC8E4F51D9
RoughCam IP1365 → AXIS P1365 - ACCC8E29187A	89.0.0.107	ACCC8E29187A
Test08 Axis M1145-L	89.0.0.110	ACCC8E3B8197
IO Module - Axis P8221	89.0.0.194	00408CADBE0C
Show room - ExCam IPQ1755 (right monitor)	89.0.0.47	ACCC8E0E0E4E
RoughCam IPQ1656 → AXIS Q1656 - ACCC8E4F68A2	172.22.21.61	ACCC8E4F68A2
AXIS M3014 - ACCC8E2CB572	89.0.0.208	ACCC8E2CB572
Outdoor - Bus stop - Axis P1346	89.0.0.152	00408CD65BF8
Test10 ExCam IP1354	89.0.0.112	00408CF23CCC
Bunker - ExCam vario (Axis Q7401)	89.0.0.144	00408CA1A3A0
Show room - ExCam miniZoom (left monito...	89.0.0.46	00408CCC0845
AXIS Q7404 Channel 2 - 00408CCC0843	89.0.0.43	00408CCC0843
Process - ExCam vario (Axis Q7404_1)	89.0.0.51	00408CCC0842
Hall - Axis 233D	89.0.0.122	00408C82E5C1
Engine room - ExCam IPM1145-L	89.0.0.140	ACCC8E39C80C
Test13 ExCam IPQ1755	89.0.0.115	00408C8F18E9
Outdoor - Gate N - Axis P1346	89.0.0.154	00408CD65BFA
Show room - ExCam IPM1145 SmokeCatche...	89.0.0.211	ACCC8E3C5A47

Fig. 8-1 Axis IP Utility

7.3 Password/ Identification

The following user name is set at the factory: **root**

The following password is set at the factory: **root**

8 Maintenance/ Modification/Repairs

The applicable regulations for the maintenance and servicing of electrical devices in potentially explosive atmospheres must be adhered to.

The required maintenance intervals are specific to the individual devices. The operating company has to determine these intervals depending on the application parameters. The maintenance tasks especially include examination of parts on which the ignition protection depends (e.g., proper condition of the casing, seals and cable entry points). If maintenance measures are necessary they have to be initiated and/or executed.

Repairs must only be carried out in accordance with nationally applied regulations by SAMCON Prozessleittechnik GmbH or by an electrical technician authorized by SAMCON Prozessleittechnik GmbH. Rebuilding of or alterations to the devices are not permitted. If in doubt, send the part in question back to SAMCON Prozessleittechnik GmbH.

9 Disposal/ Recycling

When disposing of the device, nationally applicable regulations must be observed.

This Document is subject to alterations and additions.

10 Drawings & 3D models

All drawings, 3D models and other information are available in the download area of the product page on our website:

Quick link:

<https://www.samcon.eu/en/products/roughcam/roughcam-ipq1656/>

[Products](#) / [Robust Cameras \(non-ex\)](#) / [RoughCam IPQ1656 \(DLPU\)](#)

Analog Ex Cameras (CVBS)

Network Ex Cameras (TCP/IP)

Robust Cameras (non-ex)

- RoughCam miniTube
- RoughCam e.Vario
- RoughCam IPM3016
- RoughCam IPM1137-LE
- RoughCam IPM2036
- RoughCam IPP1275
- RoughCam IPP1377
- RoughCam IPQ1615
- RoughCam IPQ1656 (DLPU)**
- RoughCam IPQ1715
- RoughCam IPQ1785
- RoughCam IPP1280 (thermal)

Your Individual Camera (BTO)

- Ex Luminaires
- Robust Luminaires
- Ex-d Camera Enclosures
- Connection Systems
- Cables for Ex-Areas
- Mounting Systems
- Wash and Wipe Equipment

Downloads:

- [Comparison Chart](#)
- [Datasheet](#)
- [3D-Model](#)
- [Usermanual](#)
- [CAD-files \(DXF\)](#)
- [Drawing](#)
- [Datasheet coolJacket](#)
- [Dec. of Conformity](#)

RoughCam® IPQ1656

The RoughCam IPQ1656 is a powerful IP-megapixel camera (4 megapixels) for use in industrial areas – **not only offering superb QuadHD resolution (2688 x 1512 at 60/50 fps) but also a powerful remote zoom and focus lens.** The RoughCam IPQ1656 combines excellent image and video performance with outstanding hardware and processing capabilities. It is equipped with a Deep Learning Processor Unit (DLPU). Thanks to **Artificial Intelligence (AI)** with **Deep Learning** perfect for analytic applications. It can differ between different objects, for example a bus, a car, a person. Furthermore it supports 3rd-party AI applications. Besides a variety of intelligent analytic features help you to make smart decisions it delivers unparalleled light sensitivity (0.05 lx). The RoughCam series is made to work under the harshest conditions in the world.

Features.

- Extremely robust and resistant
- Deep Learning Processing Unit (DLPU) for Artificial Intelligence (AI) Applications
- Object Analytics
- AI-based Dynamic Privacy Shield
- Arctic-Temperature-Control (-60°C)
- Single-Cable-Solution (PoE / 24VDC)
- Protection Level of IP68 (IEC 60529)
- High Resolution: 4MP (QuadHD) with up to 60fps)
- Unparalleled Light Sensitivity with 1/1.8" Sensor
- Lightfinder 2.0 and Forensic WDR Technologies
- Easy VMS Integration
- Electronic Image Stabilization (EIS)
- [Extensive Accessories](#)

Extremely robust IP-camera for use in the harshest conditions of the world

Thanks to the high-quality and precisely processed materials, the RoughCam series is extremely robust, impact-resistant, resistant to a variety of liquids and gases and can withstand some adverse environmental conditions.

Media resistance and seals

Due to the high-quality materials used for the T10 Series, it meets the requirements of a comprehensive media resistance list! The particularly designed GYLON (PTFE) flat sealing does not only ensure the housing to be watertight (IP68) but also supports the resistance towards several chemicals. The extremely robust and scratch-proof as well as high-impact resistant borosilicate glass fits perfectly into the high-quality materials of the housing body.

If you wish additional technical information, please contact us at:

support@samcon.eu

11 Further documentation

Further documentation is available in the download area of the product website:

<https://www.samcon.eu/en/products/roughcam/roughcam-ipq1656/>



SAMCON

Schillerstrasse 17, 35102 Lohra-Altenvers, Germany
www.samcon.eu, info@samcon.eu
Phone: +49 6426 9231-0, fax: - 31

