



SAMCON
Prozessleittechnik GmbH

Assembly Instruction

product: CMB VA4 - TNXCD
author: S. Weber
date: March 29, 2023
update: -
doc ID: 230329-PT95MA-SW-CMB VA4 - TNXCD_assembly
instruction_rev.oo.idw
passing:



INTRO

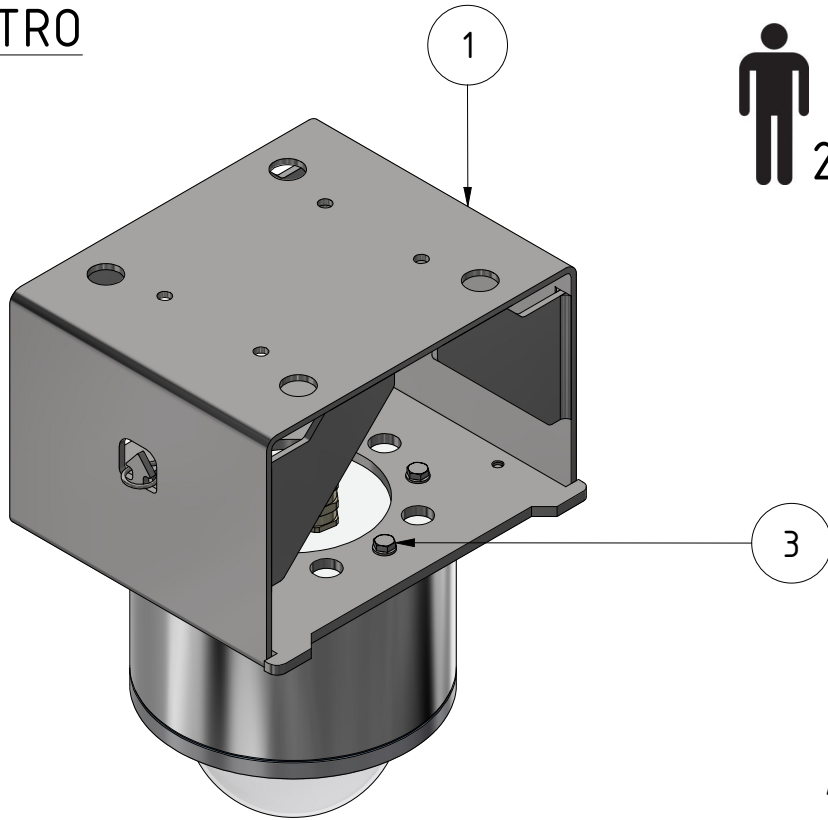

What you need:	
Wrench	13mm
Torque wrench	13mm

ATTENTION:

Please be careful when working at heights !



*Not-included fastening parts required!
Threaded bolts M10
for individual ceiling
mount*

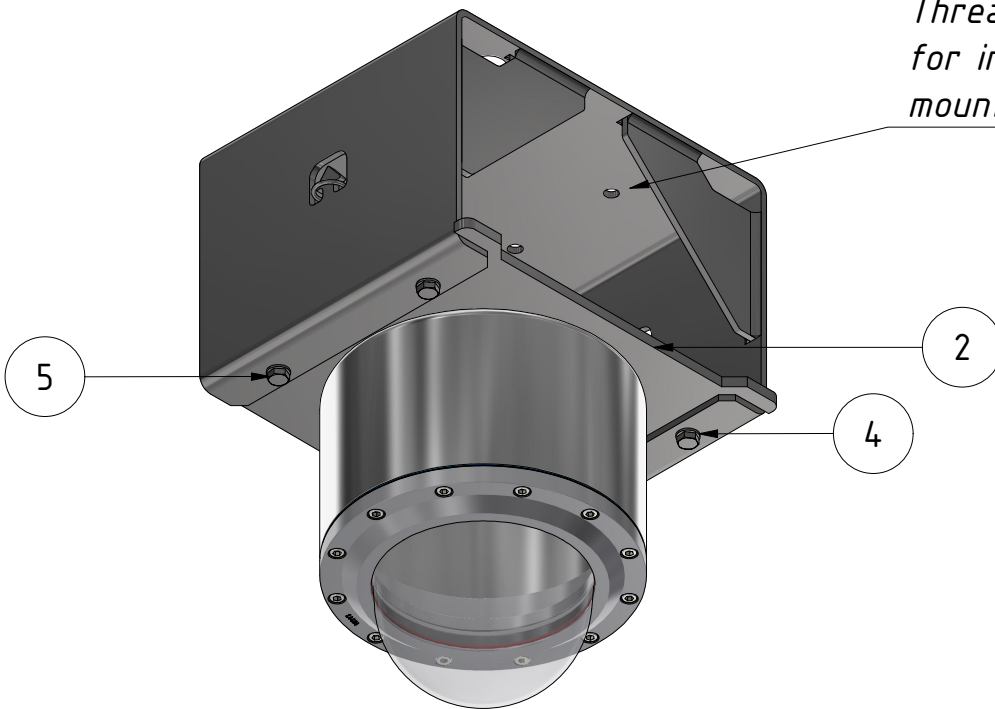
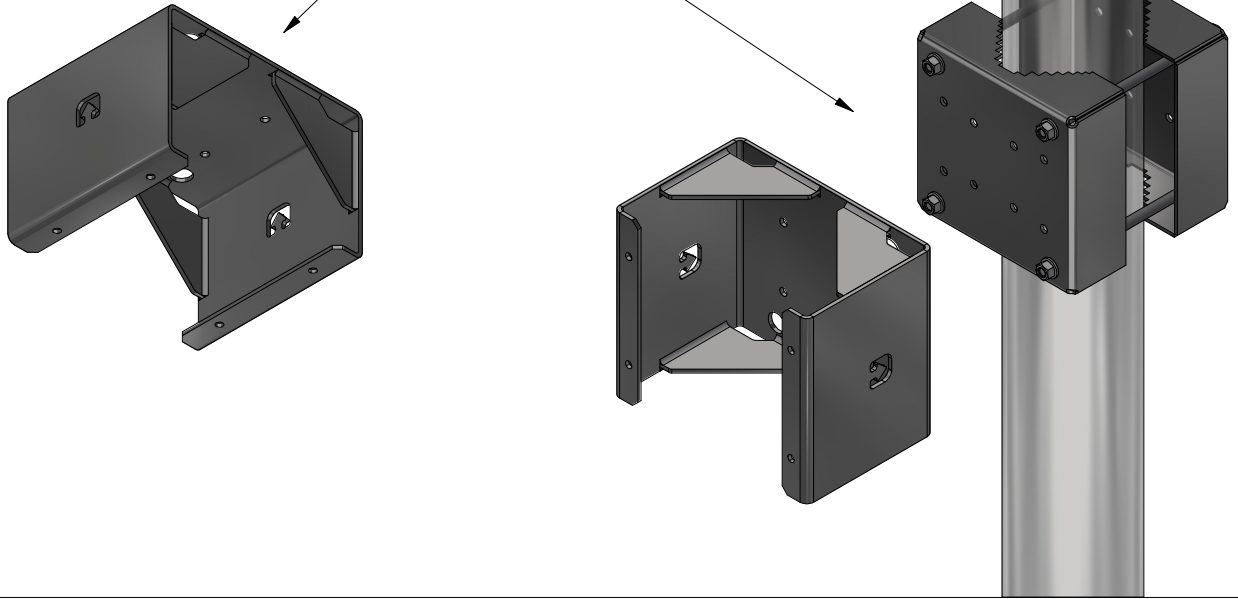

Table of content			
obj.	qty.	part	material
1	1	CMB VA4 - TNXCD part I	stainless steel
2	1	CMB VA4 - TNXCD part II	stainless steel
3	5	Threaded bolt ISO 4017 - M8 x 16	stainless steel
4	9	Washer DIN 125 - A 8,4	stainless steel
5	4	Threaded bolt ISO 4017 - M8 x 12	stainless steel

1

Fix to ceiling or to PMB!



2

tightening: 15Nm

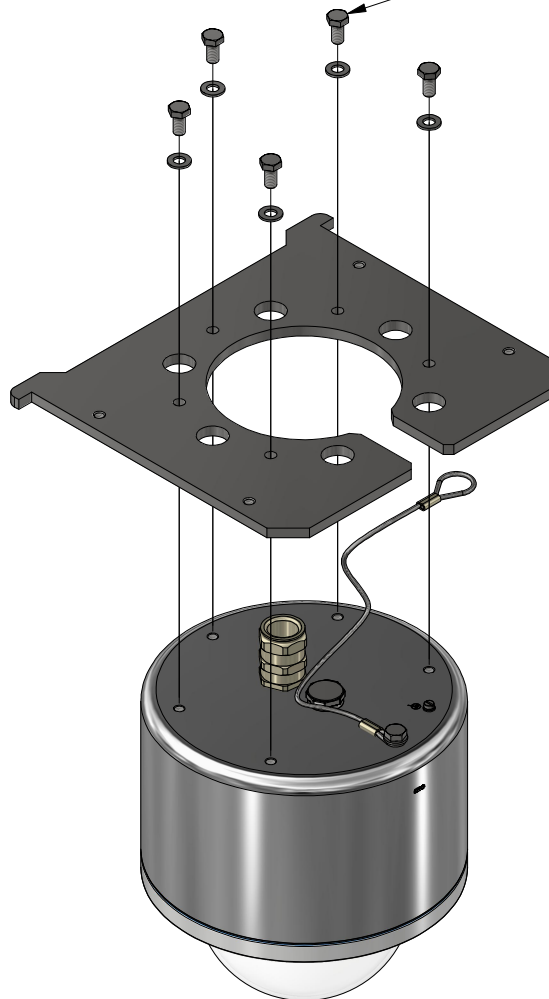

3

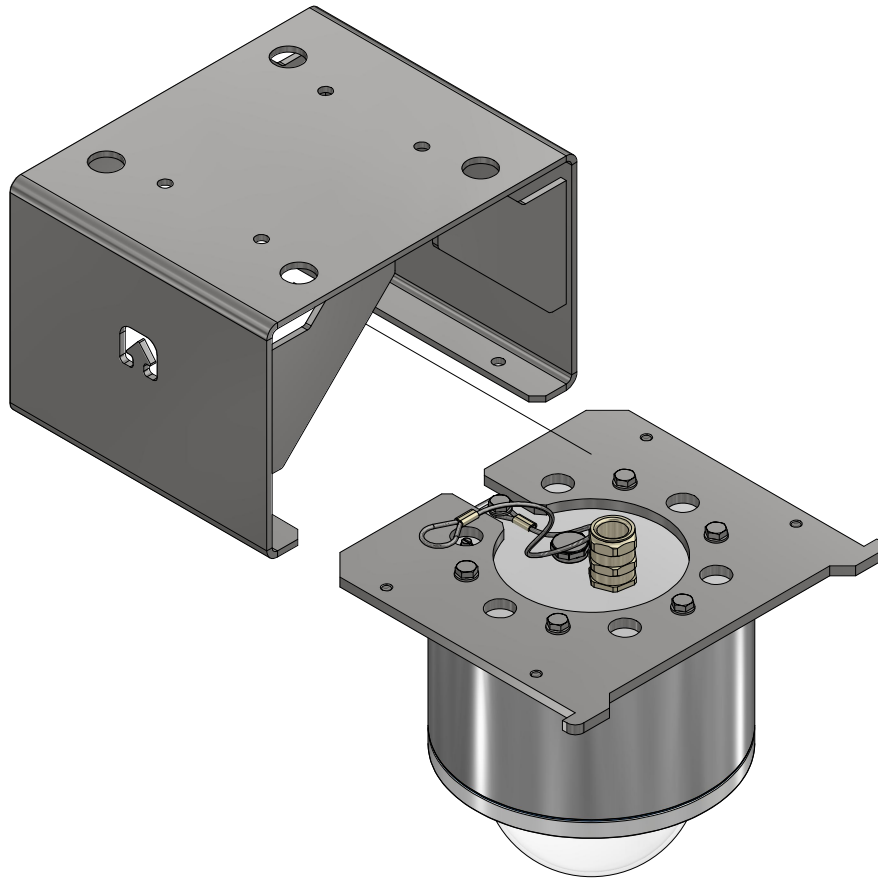

4

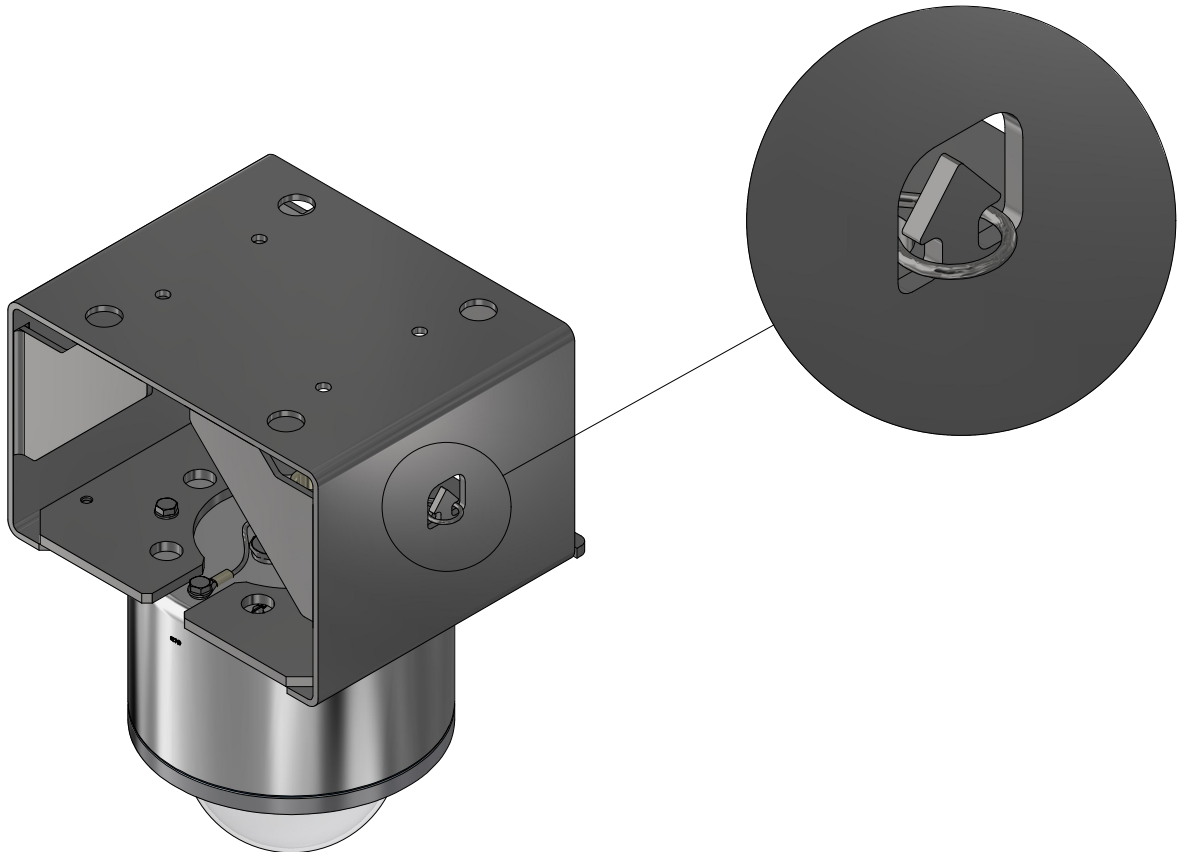

5

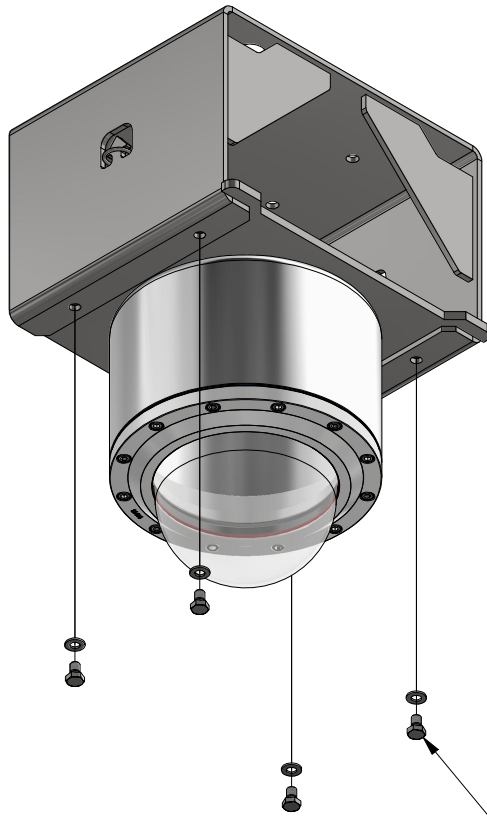

tightening: 15Nm

6

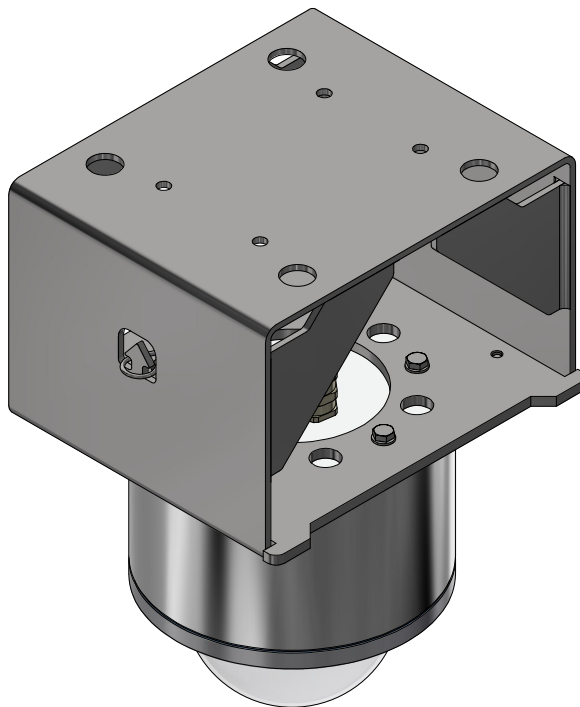

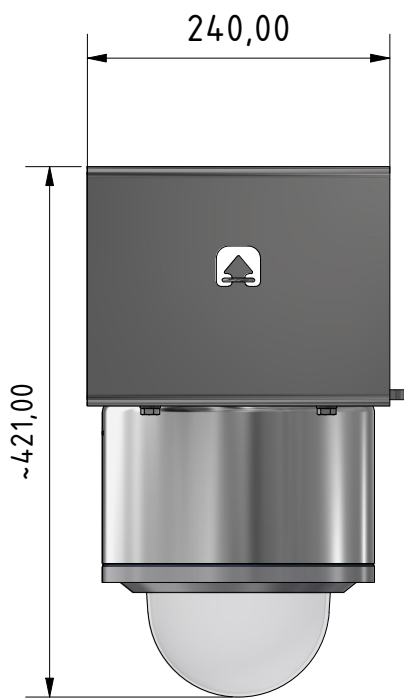

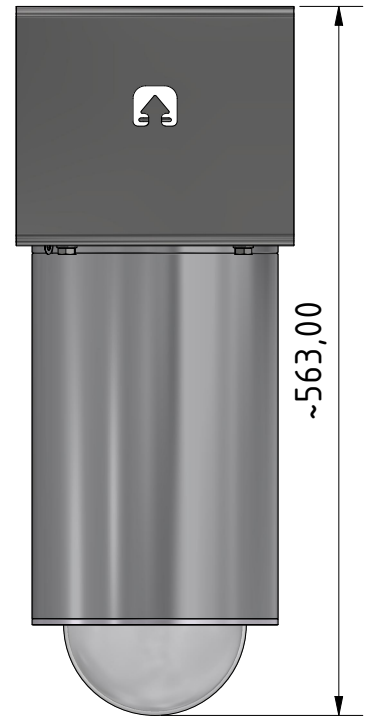
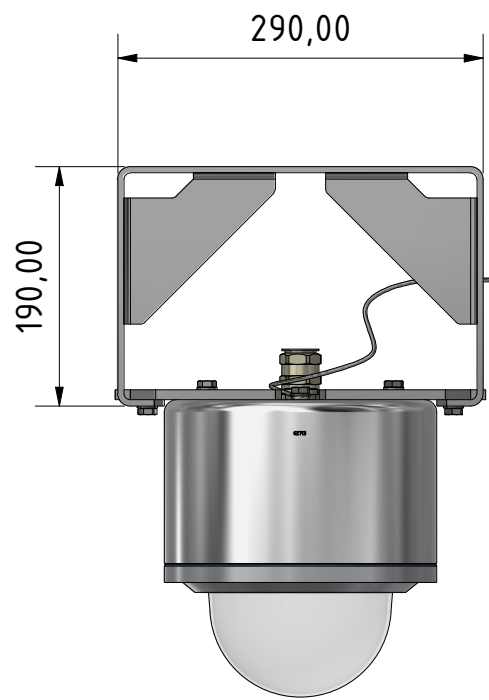

VA4 housing

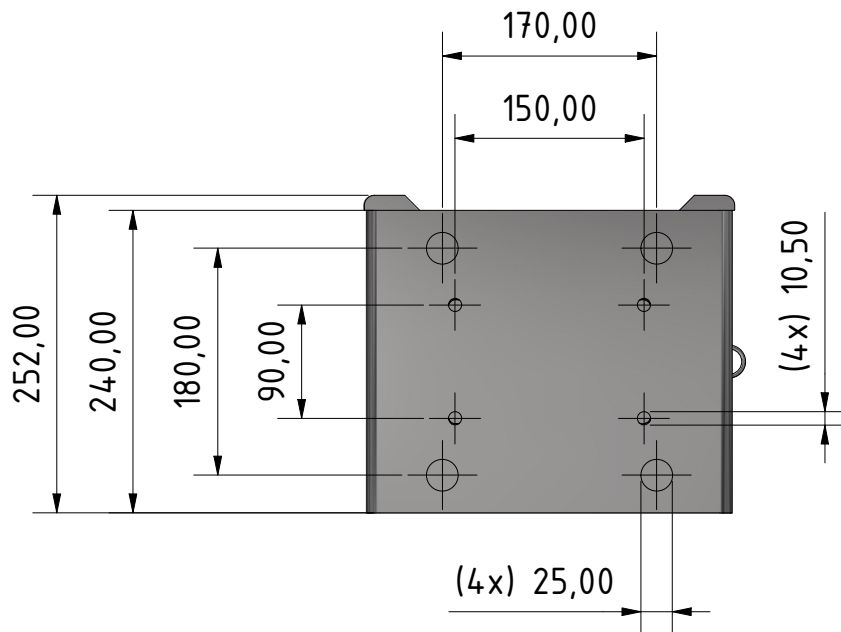

TNXCD housing





Note:
For more information see
other assembly instructions!



SAMCON

Prozessleittechnik GmbH

